

## FTHS01 intelligent temperature and humidity transmitter manual

### ■ Summary

The product adopt high quality digital sensors, with reliable performance, high precision, small year drift, fast response. It is suitable for temperature and humidity measurement of communication rooms, offices, workshops, warehouses, hospitals, HVAC, and building automation etc.. The instrument is wall-mounted or ceiling-mounted and easy to connect.

### ■ Main technical parameters

Measured range	Temperature: -20℃-80℃; Humidity: 0-100%RH, When the sensor is external, temperature range is -40-120℃
Resolution	Temperature: 0.1℃, Humidity: 0.1%RH
Accuracy	Temperature: ±0.5℃, Humidity: ±3%RH
Supply voltage	8-24VDC, Current<30mA
Ambient condition	Temperature: -20-70℃, humidity: 5-95% RH max, non-condensing
External dimensions	45x65x28mm
Mounting	Din rail, screw
Work area	10-20m <sup>2</sup> , Installed in air circulation
Weight	About 60g
Case material	PC+ABS
Optional function	
RS485 communication	RS485 interface, Standard Modbus RTU

### ■ External dimensions and terminals definition

1. External dimensions: Unit: mm

2. Terminals definition

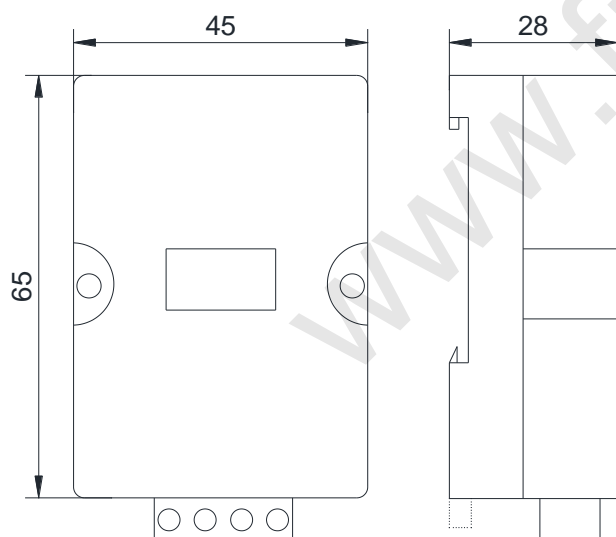

Terminals definition no	1	2	3	4
Mark	GND	VCC	B	A
Description	-	+	RS485 -	RS485 +
	RS485 communication		Auxiliary power	

### ■ RS485 communication

1. Code system

8-bit binary, hexadecimal 0-9, A...F. Each 8-bit message field contains 2 hexadecimal characters.

2. MODBUS-RTU bits per byte in the protocol:

1 start bit
8 data bits, the least valid bit should be sent first
No parity
1 stop bit

Error detection domain:

CRC-16 (cyclic redundancy check), low byte is in front, high byte behind

3. Communication baud rate in MODBUS-RTU protocol: 1200, 2400, 4800, 9600, 19200BPS. Communication baud rate and address change can be set by communication protocol.

4. Functional domain code in MODBUS protocol:

Function code	Name	Description
03	Read holding register	Reading measured data
06	Preset single register	Set the communication address, baud rate

5. Function code 03: Read holding register, reading measured data Start address of data: 0000~0001

Data length: 0001 ~ 0002, out of range is invalid; data start address + data length is not greater than 2, out of range is invalid. Note: The data that read is 16-bit data, High byte is in front, low byte behind.

Data definition: See function code and data comparison table 1.

Example 1, reading measured data:

Command:	01	03	00 00	00 02	02	CRC
	ADDR	Function	Start address	Number of registers	Byte count	CRC check
Response:	01	03	04	00 EA	02 95	CRC 11 bytes
	ADDR	Function	Byte count	Temperature	Humidity	CRC check

Calculation of the measured value: The output value is DataN/10, which is %RH or °C.

Example 1: The temperature measured value is 00EAH, the actual temperature is 00EAH/10 = 23.4°C, and the negative temperature is represented by the complement

Humidity measured is 0295H, the actual humidity is 0295H/10 = 66. 1%RH

Table 1: Function code 03H and data comparison table:

Address	Data content	Data description
0000	Temperature	Temperature data, two bytes, high byte is in front, low byte behind
0001	Humidity	Humidity data, two bytes, high byte is in front, low byte behind

6. Function code 06: Preset register, setting communication address, baud rate

Data start address: 00 00

Data length: 00 01, not equal to 00 01 The command is invalid.

Description: Set the module communication address and baud rate.

Data definition: See function code and data comparison table 2.

Example 2, preset module communication address, baud rate (set the address of module No. 1 to No. 2, the baud rate is 9600 BPS)

Command:	01	06	00 00	00 01	02	02 06	CRC
	ADDR	Function	Start address	Number of registers	Byte count	Preset data	CRC check
Response:	01	06	00 00	00 01			CRC
	ADDR	Function	Start address	Number of registers			CRC check

Table 2: Function code 06H and data comparison table.

Address	Data content	Data description
0000	ADDR, BPS	The high 8 bits are the module communication address, address range is 01~F7H; the low 8 bits are the communication baud rate, the value is 03~07H, which means 1200~19200BPS.